

1. Product drawing

2. Scope:

This specification is applicable to EXTREME lithium and iron disulfide battery, FR03 distributed under brandname RAVER.

3. Law & Regulation Compliances:

This product complies with EU's battery directive (2006/66/EC).

Packaging materials comply with EU's directive on packaging materials and waste (94/62/EC)

4. Appearance

The battery visually inspected by unaided eye 30cm away from battery. The battery shall be free from dents, scratch, rust and extruded internal compounds, such as sealing compounds and etc, and serious displacement of artwork. Appearance defects shall not be observed that may adversely affect actual use or performance of batteries.

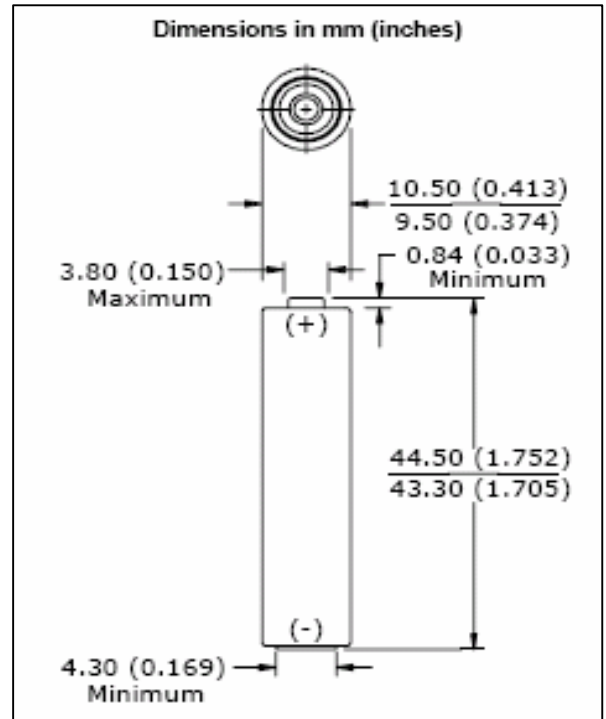

5. General:

No.	Items	Specification
1	Nominal Voltage	1.70V ~1.86V
2	Impedance	≤450mΩ
3	Typical Capacity (100mA)	1200 ±50 mAh at 100mA discharge current
4	Working Voltage	1.30V at 350mA discharge rate
5	Max. Discharge Current	1000 mA continuous
6	Discharge Cut-off Voltage	0.80V
7	Volume	3.8 cubic centimeters
8	Weight	Approx. 6.8~7.5 g
9	Lithium Content	Less than 0.5 gram per cell
10	Dimensions	Diameter: 10.0±0.5 mm
		Height: 43.9±0.6mm
11	Operating Temp.	-40 °C to 60 °C
12	Suggested Storage Temp.	-20 °C to 40 °C
13	Storage Humidity	≤75 %
14	Shelf Life	10 Years



6. Test Conditions and Performance

6.1 Measuring Instrument or Apparatus

6.1.1 Dimension Measuring Instrument. The dimension measurement shall be implemented by calipers with equal or more precision scale of 0.01 mm.

6.1.2 Voltmeter. Standard class specified in the national standard or more sensitive class having inner impedance more than 10kΩ/V.

6.1.3 Ammeter. Standard class specified in the national standard or more sensitive class. Total external resistance including ammeter and wire is less than 0.01Ω.

6.1.4 Standard Test Conditions

Unless other defined, test and measurement shall be done under temperature of 20±5°C and relative humidity of 45~85%. If it is judged that the test results are not affected by such conditions, the tests may be conducted at temperature 10~30°C and humidity 25~85%RH.

6.2 Mechanical characteristics

No.	Item	Test Method	Criteria
1	Impact	A 15.8 mm diameter bar is vertically placed across the centre of the sample cell. A 9.1kg mass is dropped from a height of 61cm onto the sample.	No explosion, No fire
2	Vibration	Freq: 10~55hz; Amp: 2mm; Three directions; total 90 min	No leakage, No explosion, no fire 0.02V total maximum OV changes
3	Crush	A sample cell is to be crushed between two flat surfaces. Force: 32mm diameter piston; Max pressure: 17.2MPa; Max force: 13KN; Released when the max pressure obtained.	No explosion, No fire

6.3 Environmental test

No.	Item	Test Conditions	Criteria
1	Thermal test	Fresh batteries, store at 70 deg. C for 4hs; 20 deg. C for 2hs; -20 deg. C for 4hs; 20 deg. C for 2hs. All cycled 5 times	No leakage No explosion; No fire



2	Heating test	Fresh battery is heated in an oven. The rate of temperature raised: $5\pm 2^{\circ}\text{C}$ per minute; Max. temperature $150\pm 2^{\circ}\text{C}$ remaining for 10 minutes.	No explosion; No fire
3	Drop test	Fresh batteries; Height: 1m, 6 times; Each direction two times; Concrete floor	No leakage; No explosion; No fire

7. Discharge diagram

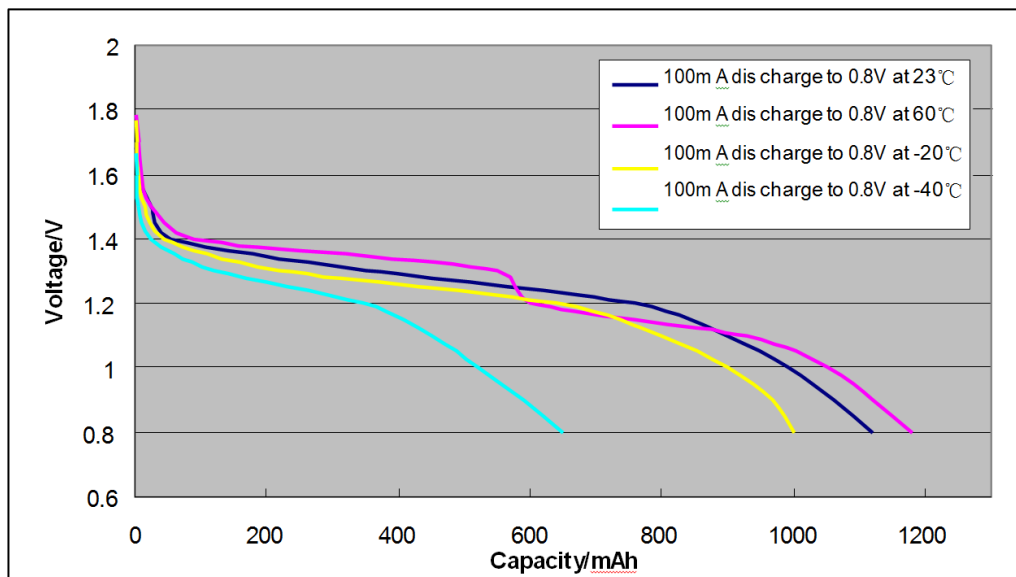
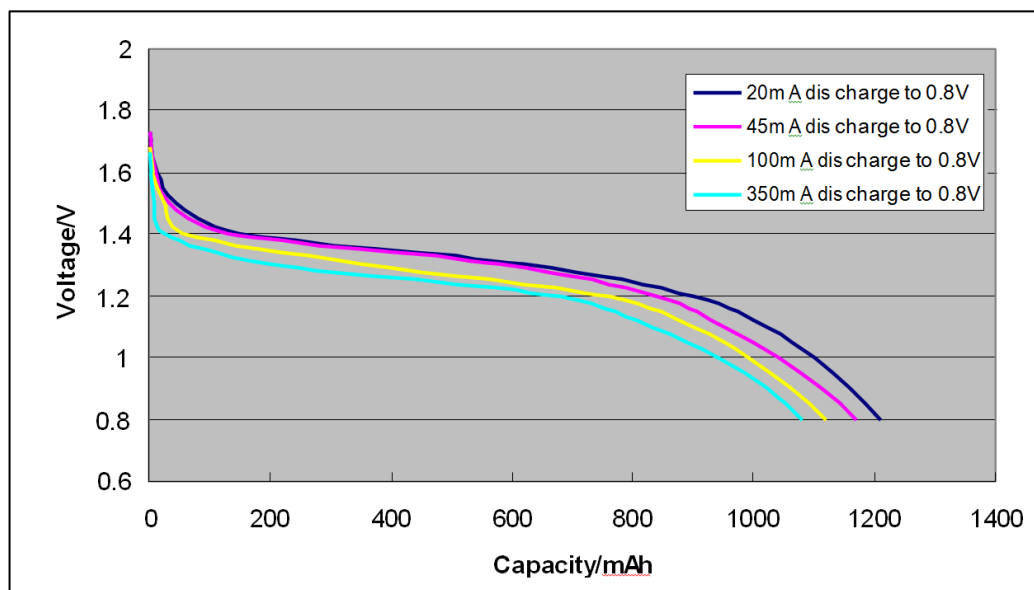

8. Cautions in use

- To ensure proper use of the battery please read the manual carefully before using it.
- Do not expose to, dispose of the battery in fire.
- Do not put the battery in a charger or equipment with wrong terminals connected.
- Avoid shorting the battery
- Avoid excessive physical shock or vibration.
- Do not disassemble or deform the battery.
- Do not immerse in water.
- Do not use the battery mixed with used or other different make, type, model batteries.
- Keep out of the reach of children.
- Store the battery in a cool, dry and well-ventilated area.
- Regulations vary for different countries. Dispose of in accordance with local regulations.

9. Battery operation instruction

9.1 Discharging current

The discharging current does not have to surpass this specification book stipulation the biggest discharging current, the oversized electric current electric discharge can cause the battery capacity play to reduce and to cause the battery heat.

9.2 Electric discharge temperature

The battery discharge must carry on in the ambient temperature scope which this specification book stipulated.

9.3 Storing the Batteries

The battery should store in the product specification book stipulation temperature range. If has surpasses above for six months the long time storage, the discharge capacity will decrease sharply.

9.4 Other Chemical Reaction

Because batteries utilize a chemical reaction, battery performance will deteriorate over time even if stored for a long period of time without being used. In addition, if the various usage conditions such as discharge, ambient temperature, are not maintained within the specified ranges the life expectancy of the battery may be shortened or the device in which the battery is used may be damaged by electrolyte leakage. Please change the battery in time.

10. Packaging Requirements

10.1 The total of heavy metal lead, cadmium, mercury, and hexavalent chromium concentration shall not exceed 100 ppm in Packaging materials and printing inks. Ozone depleting substances (ODS) shall not be used in the manufacturing of any packaging.

The printing on each cell label is legible and permanent. Label defects, if any, shall conform to mutually agreed upon limit samples.

10.2 It is recommended that packaging for shipment and sales according to following packaging specification: 2pcs cells in a blister, 14 blisters in a display box, 10 display boxes in a final outer carton.

10.3 Otherwise packaging for shipment and sales shall conform to the mutually agreed to packaging specification of the designated customers.

